

FISCHBEIN BAG CLOSER

Instruction & Parts Manual
Model 90

The Don Marshall Company, Inc.
235 Maple Street - PO Box 124
Plain City, Ohio 43064
614-873-8520, Fax: 614-873-8338
info@donmarshall.net

TABLE OF CONTENTS

Installation	4
Motor Recommendations	
Initial Lubrications	
Cool Area Operation	
Running After Prolonged Shut-Down	
Adjustments	5
Threading	
Tensions	6
Needle Thread Pull-Off	
Needle Replacement	
Needle Chuck	
Stitch Length	7
Looper Timing	8
Looper Holder	
Needle Guard	
Presser Foot Spring Pressure	9
Leveling the Presser Foot	
Feed Dog Replacement	
Feed Dog Adjustment	
Knives Adjustment	10
The Gauge	11
Maintenance	12
Oil	
Changing The Oil	13
Seals	
Cleaning	
Trouble Shooting	14
Synchronization	
Oil	15
Skipped Stitches	
Loose/Tight Stitches	
Uneven Stitches	
Wear On Essential Parts	
Machine Not Chaining Off	16
Frequent Needle Breaks	
Diagrams	
Threading Diagram	5
Bottom Plate Assembly	7
Scarf of the Needle	8
Looper Holder	8
Needle Guard	8
Shearing Knives Assembly	10
Scissor Assembly	10
Feed Dog Height	11
Height of the Needle Stroke	11
Checking the Timing of the Looper	11
Oil Check/Change Assembly	12

Synchronized Sewing Head Operating Speed	17
Main Housing Assembly	18
Needle & Presser Foot Assemblies	20
Lever Housing Assembly	22
Feed Assembly	24
Main Shaft & Knife Assembly	26
Looper Assembly	28
Oil Pump Assembly	29

INSTALLATION

MOTOR RECOMMENDATIONS

A 1/2 H.P. 1725 RPM motor is capable of operating this head up to 1800 RPM. Beyond 1800 RPM a 1-1/2 H.P. 3450 RPM motor is required. The variable pulley on the sewing head permits speed adjustments. Changing motor pulley diameter may be required. Sewing head pulley must rotate clockwise. It is necessary to mount this head securely. Maximum RPM is 2200.

INITIAL LUBRICATION

Individual heads are shipped with a screw in the vent plug opening. This must be removed before running machine. (Sewing heads shipped as part of a system do not have the screw.)

The sewing head is shipped from the factory oil filled. At the beginning of each day or shift check that oil is visible in the oil level window prior to start-up. Turn the machine on. After 30 seconds, the oil pressure gauge should read in the normal 20 to 40 pound range. Maintain oil at the level line during operation. **Never run machine if the oil pressure gauge is below 10 pounds P.S.I.**

COOL AREA OPERATION

In cool areas allow the machine to warm up by running steadily for a few minutes before closing any bags. Failure to do this, especially with units running on single phase current, can result in slow starting and running of the sewing head. This can cause mis-synchronization with the speed of the conveyor belt which will break thread and cause sewing problems until the sewing head warms-up and attains proper speed.

If the temperature is approximately 35 degrees Fahrenheit or below, it may be necessary to warm the sewing head at the bottom with an auxiliary heat source such as a heat lamp.

RUNNING AFTER PROLONGED SHUT-DOWN

After prolong shut-down periods, the sewing head oil should be pumping properly and the sewing head warmed up before closing any bag. This is easily accomplished by running the sewing head in short 2 - 3 second cycles until the oil pressure gauge reads in the normal 20 - 40 pound range.

ADJUSTMENTS

THREADING

First be sure the machine is turned off and the power source is disconnected. To thread the machine properly follow the diagram (see Drawing 1 or diagram on the side of the machine). The thread goes into the needle from the side where the bag enters the machine.

The looper thread should pass up and over the looper thread tension. As with the needle lever tension, there should be only a very slight pull on the thread. The thread is then routed down and through the thread guide, behind the plate, through the thread pull-off and then through BOTH HOLES of the looper.

The machine is now ready to sew. However, on a newly threaded machine there is no thread chain (a small length of chained stitches). In this case, sewing must begin on material, otherwise the thread will tangle around the looper. Raise the presser foot by pushing the lifter lever and place material under the presser foot. Check the looper and make sure no thread has massed around it. Lower the presser foot and begin to sew.

DRAWING 1

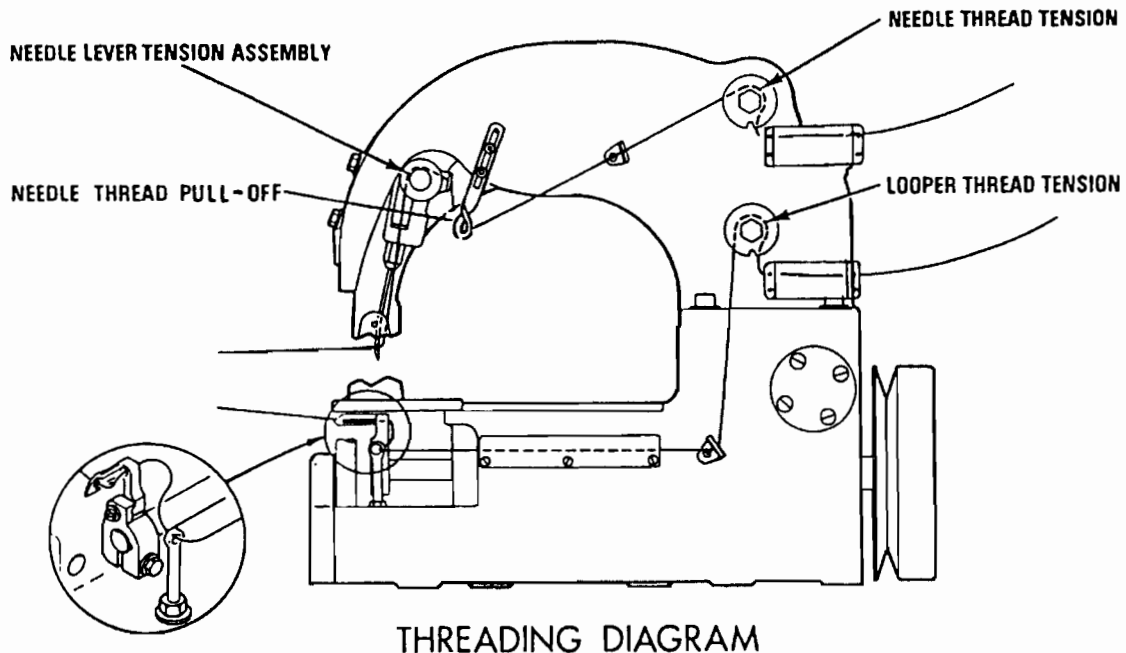

TENSIONS

The looper tension must be very light, barely discernible when pulling the thread by hand.

The needle thread tension should be very firm and put a noticeable drag on the thread.

The tension assembly, located on the needle lever, must put only light pressure on the thread, about the same as the looper tension. This tension assembly is **not** adjustable.

NEEDLE THREAD PULL-OFF

This adjustment can vary with different lengths of stitches, bag thickness, and type of thread. The normal setting for a two thread machine is 1-1/4 inches from the center of the thread hole to the first fastener screw.

If the stitching on the bag is noticeably loose, raise the pull-off; if it is too tight, lower the pull-off.

NEEDLE REPLACEMENT

A good needle is essential for optimum performance of the machine. If the needle becomes bent, dull or worn, it should be replaced.

To replace the needle, first, loosen the needle set screw using the small needle wrench provided with the machine. **CAUTION:** Use the small needle wrench only. A larger wrench will apply too much pressure on the needle set screw, damaging the screw, the needle chuck, or both.

Remove the old needle. Insert the new needle into the needle chuck. Be sure it is inserted as far as it will go. Using the needle wrench again, lock the needle set screw against the flat of the needle shank.

NEEDLE CHUCK

If the needle chuck has been removed for any reason, it is important to make sure that the depth of the chuck and the rotation of the chuck are correct.

The depth of the chuck is correct when the bottom of the eye of the needle is 1-1/8" above the throat plate at the highest point for the 90 and 91 models. You can verify this distance with the gauge supplied by Fischbein in the tool kit.

Rotation of the chuck is correct when the head of the screw is parallel with the side of the housing.

STITCH LENGTH

The stitch length may be adjusted from 2 to 3.5 stitches per inch. Stitch length must be appropriate for the content of your bags. Stitches which are closer together than necessary weaken the bag, consume more thread, and increase the speed of the sewing head.

Whenever the stitch length is changed, the speed of the machine must also be changed.

Turn the machine off and disconnect the power source. Remove the machine from the pedestal. Tip it up so that the oil does not run out when removing the drain plug. Remove the magnetic drain plug on the bottom cover. Reach through the drain plug hole with a 3/16 inch allen wrench and loosen the socket cap screw on the feed rocker. DO NOT COMPLETELY REMOVE CAP SCREW (See Drawing 2).

To shorten the stitch length, slide the loosened cap screw towards the throat plate. To lengthen the stitches, slide the cap screw away from the throat plate.

Make sure adjusting screw is securely re-tightened.

For stitch length of two stitches per inch. Use optional throat plate and feed dog.

DRAWING 2

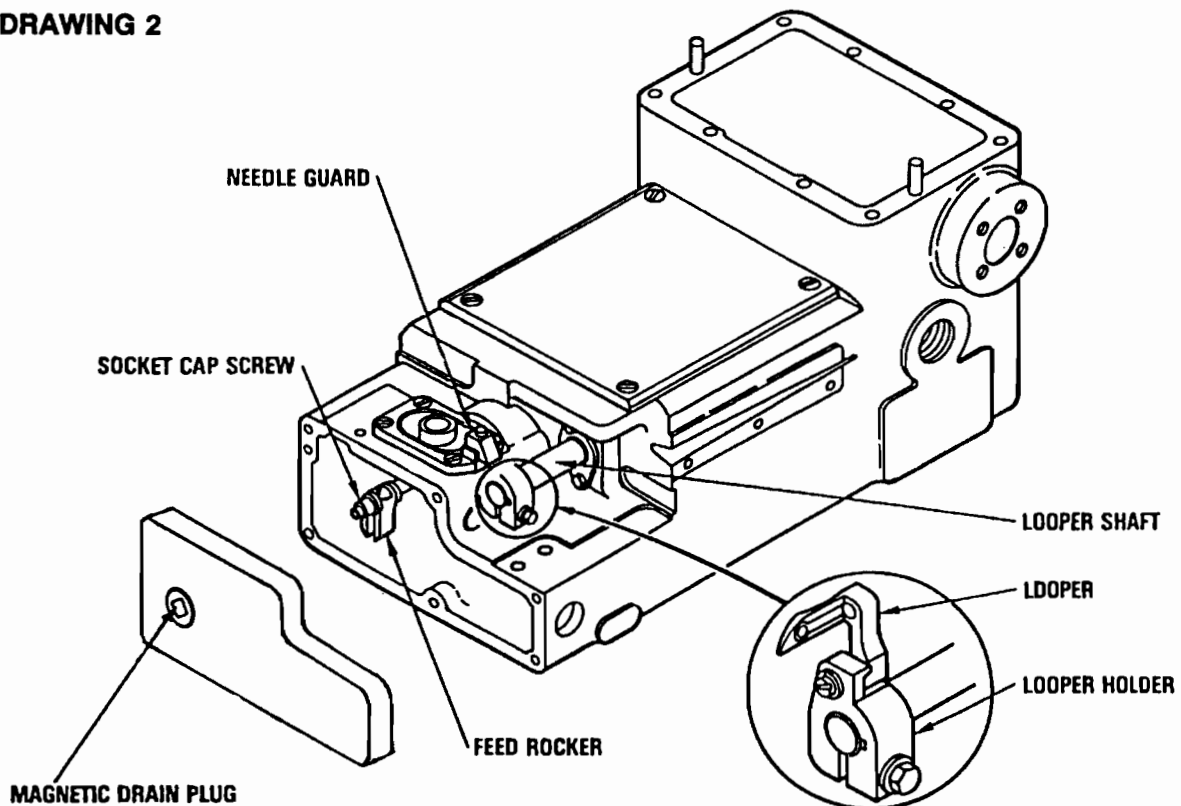

LOOPER TIMING

The looper timing is set at the factory using pointed set screws. It cannot be altered.

If you need to replace the looper, do so without changing the position of the looper holder. The looper should pass the scarf of the needle with about $1/64"$ (.015) clearance. (See Drawing 3)

LOOPER HOLDER

If the looper holder has been moved and needs resetting, it must be positioned on the looper shaft so that the point of the looper is $3/16"$ from the center of the needle when the looper is at its farthest point back (towards the pulley end of machine). (See Drawing 4)

NEEDLE GUARD

The needle guard is stationary and needs no adjustment. If it is replaced due to excessive wear or damage, it should be set so that the needle clears it by about $.005"$. (See Drawing 5)

DRAWING 3

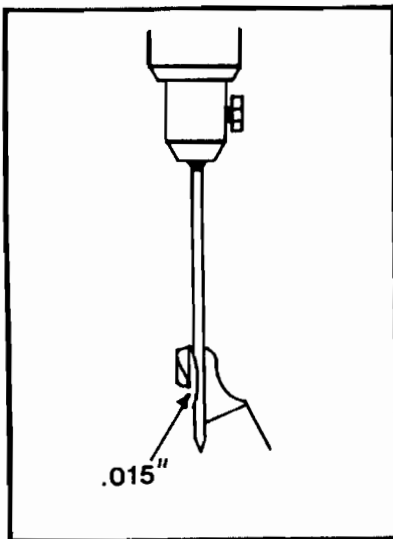

DRAWING 4

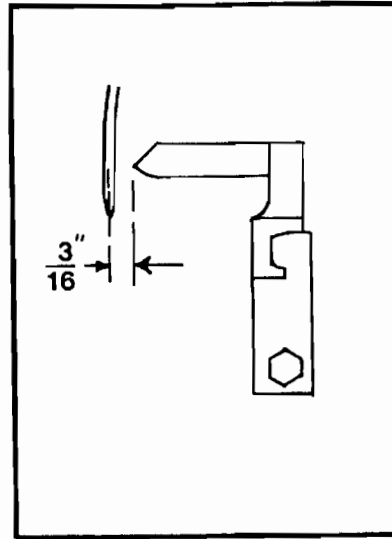

DRAWING 5

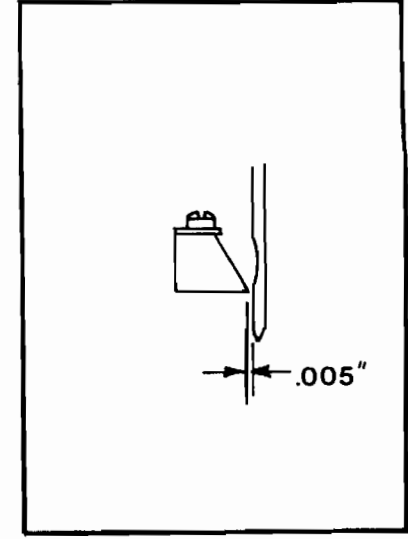

PRESSER FOOT SPRING PRESSURE

The spring pressure is the strength with which the presser foot forces the bag against the feed dog. Improper spring pressure causes improper bag feeding and chain formation.

To adjust the presser foot spring pressure, turn the hex adjusting screw on top of the lever housing.

Turning the screw clockwise will increase the pressure.

Turning the screw counter-clockwise will decrease the pressure.

Be careful not to loosen this adjusting screw too far or further maintenance will be required.

If all spring pressure is lost or unknown, turn the adjusting bolt clockwise all the way. Do not force it. Then back it off approximately 5 turns. The machine must have control of the bag.

LEVELING THE PRESSER FOOT

Whenever the feed dog height is changed due to wear, adjustment or replacement, it is necessary to level the presser foot. The presser foot must be level with the feed dog.

To level the foot, shut the machine off and disconnect the power source. Turn the pulley until the feed dog teeth are at the highest point, remove any thread from between the foot and feed dog. Loosen the screw and locknut at the rear of the presser foot so the screw has no contact with the base of the foot. Then loosen the front leveling screw in the hinge block of the presser foot. The spring pressure will force the foot evenly against both rows of teeth of the feed dog. Tighten the front leveling screw.

Next adjust the rear screw with the locknut. Pushing down on the back of the foot raising the front of the foot to allow a fifteenth thousandths (.015 in.) gauge to pass half way across the feed dog without interference from the foot.

FEED DOG REPLACEMENT

After turning off the machine and disconnecting the power source, remove the head from the pedestal and place on a table or bench. Prop up or remove the presser foot. Remove the throat plate and then the feed dog. Now, install the feed dog and tighten the set screw on the center of the flat spot on the shaft. Reinstall the throat plate and verify that the feed dog teeth are 1/16th inch above the throat plate when at its highest point. Check the alignment of the feed dog in the throat plate slots. If adjustments are necessary see **Feed Dog Adjustment**.

FEED DOG ADJUSTMENT

With the sewing head on a table or bench, drain the oil or tilt the sewing head backwards, then remove the bottom cover. With the feed dog at its highest point, loosen the feed dog carrier rod clamp, install the throat plate and raise the feed dog carrier rod until the feed dog teeth are at the required 1/16" above the throat plate. Now, align the feed dog in the throat plate slots before tightening the feed dog carrier rod.

THE DON MARSHALL COMPANY, INC.

235 MAPLE STREET P.O. BOX 124 PLAIN CITY, OHIO 43064
PH. (614) 873-8520 FAX: (614) 873-8338

KNIVES ADJUSTMENT

Dull or poorly adjusted knives cause improper cutting of thread between bags.

There are one of two types of knife assemblies available on the Model 90. The shear type assembly has two springs holding the moving blade against the stationary blade. (See Drawing 6) If these springs have collapsed and are causing poor cutting, replace them. If the stationary blade becomes dull, it can be turned over once. The other side is sharp. If the moving blade becomes dull, it can be rotated 180 degrees. This blade cannot be tipped over. If blades are dull on both sides, they must be replaced.

The scissor type assembly is held together by a spring washer and lock nut. (See Drawing 7) The correct adjustment on the lock nut is critical. Pressure on the spring washer should be no more than half collapsed. If it is, Knives must be replaced.

DRAWING 6

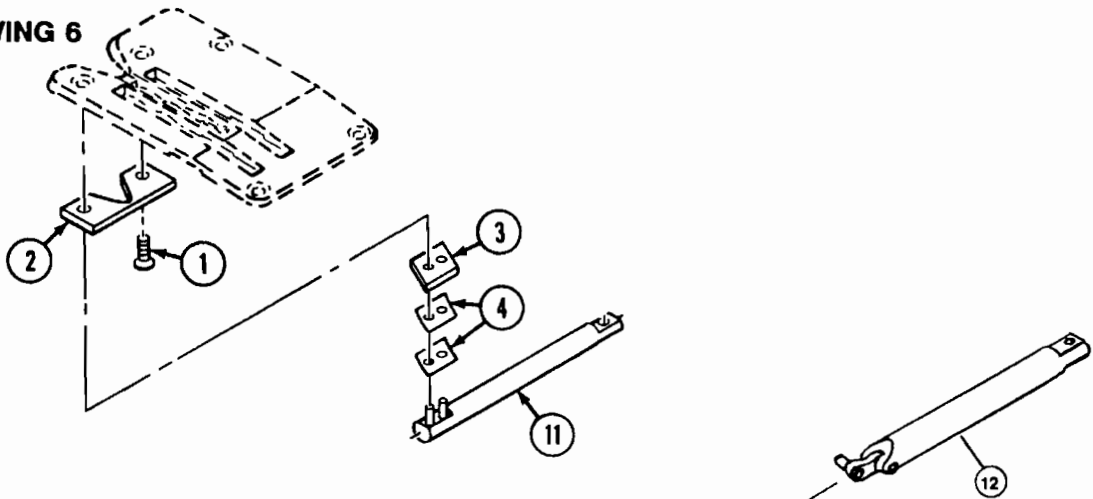

DRAWING 7

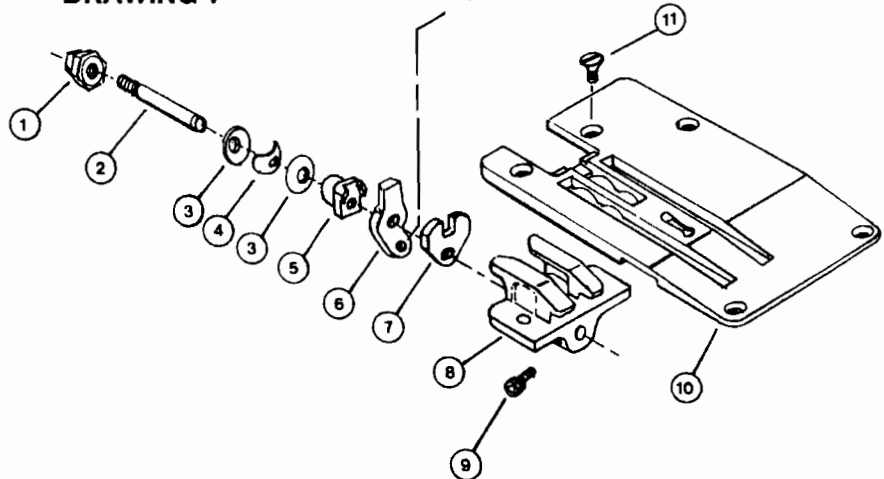

THE GAUGE

The Gauge is a necessary tool for adjusting model 90. The following should be used as a reference for your machine. The gauge (part #10230) has three important dimensions for three separate measurement functions.

The gauge thickness, $1/16"$, is used to check the height of the feed dog above the throat plate at the top of the stroke. The measurement is made with the presser foot on the machine and no thread between the foot and the feed dog. The gauge should fit between the plate and presser foot. If it does not fit, the feed dog may be worn and needs to be replaced. If it is still sharp raise it to the proper height. (See Drawing 9)

Standing the gauge on edge, check the height of the needle stroke. The needle height should be $1-1/8"$ (See Drawing 8). The throat plate must be on the machine for this check because the measurement is made from the throat plate to the bottom of the eye of the needle. This dimension is a very critical adjustment. Be sure the needle is in the chuck all the way. The cut away position, $1/4" \times 1-1/13"$, allows this chuck to be made when the feed dog is on the machine. The needle and feed dog will be at the top of the stroke at this point.

The third use of the gauge is to check the stroke or timing of the looper. (See Drawing 10) With the looper to the right of the needle as far as it will travel or with the looper retracted into the machine as far as it will go, measure from the center of the needle to the tip of the looper. The moving parts should be well oiled inside the machine at this point to reduce free travel or excessive movement of the looper. The small "V" in the gauge is now placed on the needle. The looper can be adjusted so the gauge clears the looper and that the looper is right up to the gauge.

Other Uses for the Gauge

The gauge is exactly 3" long at the longest point. This can be used as a gauge to measure stitch length.

The gauge is also a good straight edge to check the rotation of the needle chuck. It should be parallel with the machine. To check place it on the needle clamping screw. When held firmly on the screw, it should seek a straight line parallel with machine.

DRAWING 8

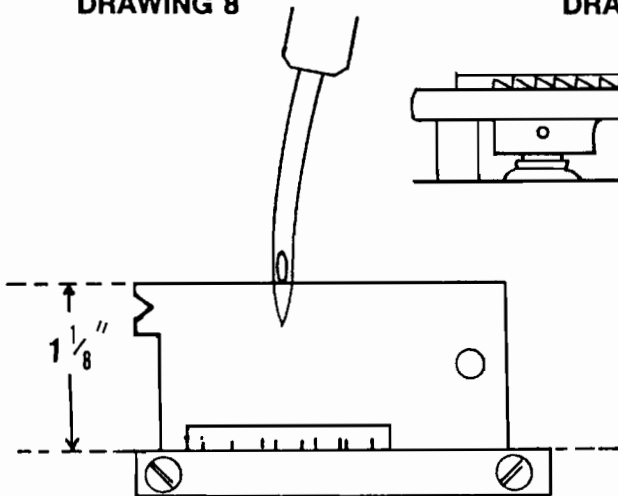

DRAWING 9

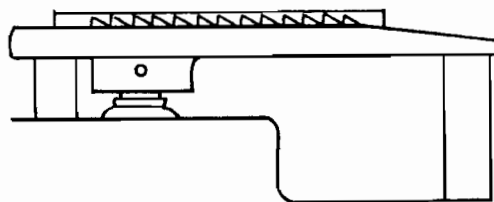

DRAWING 10

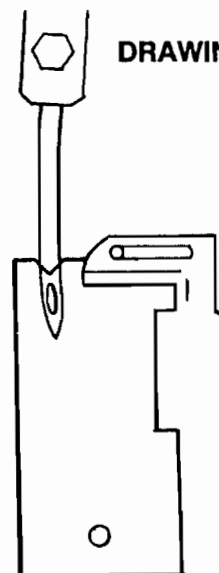

THE DON MARSHALL COMPANY, INC.

235 MAPLE STREET P.O. BOX 124 PLAIN CITY, OHIO 43064
PH. (614) 873-8520 FAX: (614) 873-8338

MAINTENANCE

OIL

Use the Special Lubricating Oil for all Model 90 sewing heads (Part # 10200). This has H2 approval by the U.S.D.A. It is available from FISCHBEIN authorized distributors. It has the lubricating specifications necessary for optimum performance. Other oils may have improper viscosity, lack U.S.D.A H2 approval and may contain additives which could cause seal damage. In addition, it is non-foaming and leaves no internal residue. In an emergency, a quality 20W motor oil may be used temporarily. 24-30 ounces of oil will fill the machine.

The model 90 has an external adjustable oil pressure relief valve. It controls the amount of pressure used to lubricate the machine. It is set at the factory and should never need adjusting. Normal range is from 20 to 40 pounds.

When adding or changing oil, remove the breather plug, located on the side of the machine. Pour oil directly into the breather plug hole until the oil reaches the "oil level" on the oil window. Then run the machine adding oil until oil level is maintained. **Never run the machine if the oil pressure gauge reads below 10 pounds P.S.I.** (See Drawing 11) Always use a clean funnel to keep foreign material out of the machine.

DRAWING 11

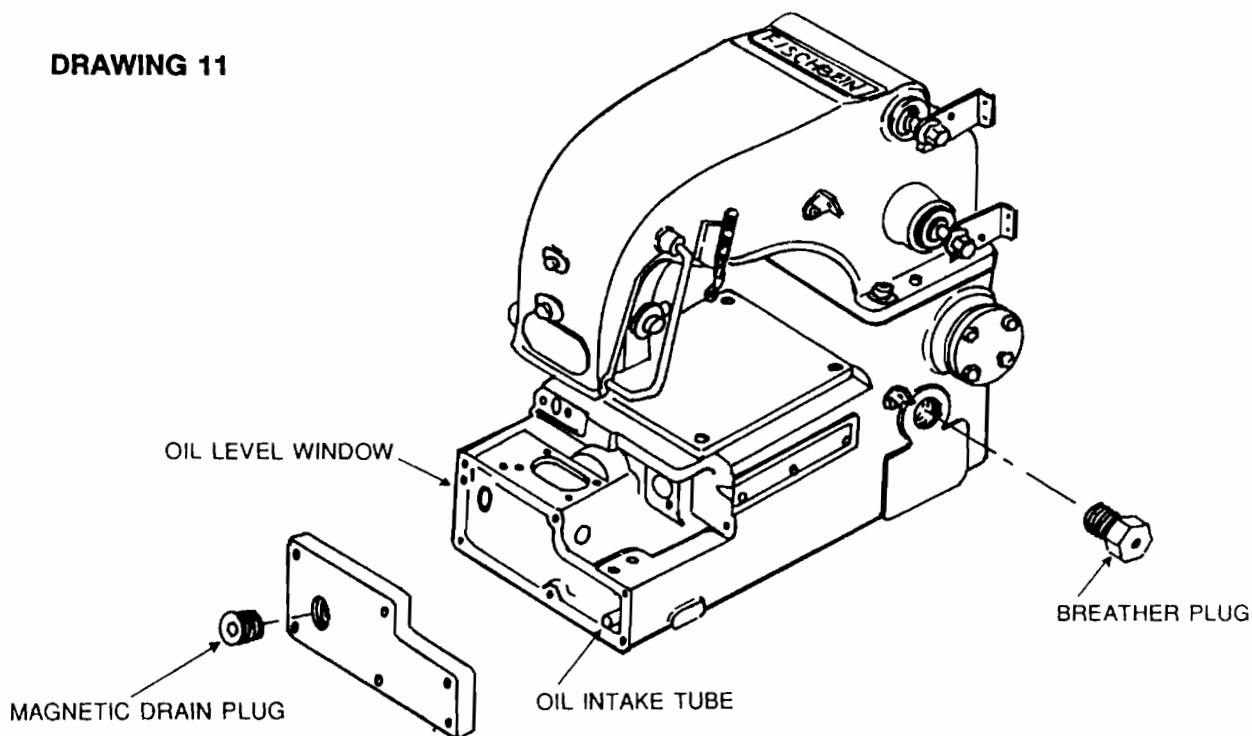

CHANGING THE OIL

To drain oil, first be sure the machine is turned off and the power source is disconnected. Remove drain plug and allow oil to drain. Change oil every **3 months** or **500 hours** of operation whichever comes first. Dirty, dusty conditions may require more frequent changes.

At oil change intervals, remove breather plug and check for free passage of air. Replace the breather plug when necessary.

Oil filters should be changed annually or more often under dirty conditions.

When changing the oil, it is a good time to clean the magnet in the bottom cover. Dirt particles can accumulate here and it is important to get rid of them.

Also recommended is periodic oiling of the pressure foot hinge bolt and surfaces of the cutting knife.

SEALS

All seals must be handled with extreme caution. Even a small amount of damage in handling or installation will permit leakage. When replacing a seal, lubricate both it and the shaft with oil before assembling. Never install a dry seal over a dry shaft.

CLEANING

Keeping the machine clean and free of excessive lint and dust is very important. The looper area, in particular, must always be kept clean. If permitted to accumulate lint for long periods of time, it can set up a wicking action which will absorb oil from the machine. Occasionally blow off or scrape such exposed parts as the Feed Dog, Throat Plate and Presser Foot.

TROUBLE SHOOTING

SYNCHRONIZATION

If machine is not sewing correctly, be sure that it is synchronized with the conveyor belt. Synchronization means the proper relationship among the speeds of the conveyor, the infeed and the sewing head.

The most accurate method of checking synchronization is to use a tachometer which reads both the "feet per minute" and the "revolutions per minute". You can check directly the speeds of the conveyor belt and the infeed belt in feet per minute.

On a 90 head one complete revolution equals one stitch or twelve (12) revolutions equal twelve (12) stitches. The number of stitches in one foot times the conveyor speed equal the number of revolutions the machine must run.

Conveyor Speed

The system is synchronized when the sewing head turns exactly the number of revolutions to match the speed of the conveyor belt. The conveyor belt usually runs at a fixed speed. The sewing head and the infeed must be adjusted to the conveyor.

Infeed Speed

The infeed should run at the same speed as the conveyor or slightly faster. Paper bags develop a slight wrinkle as they pass between the infeed and the sewing head when this synchronization is correct. The infeed is adjusted by using a variable speed pulley on the infeed motor. The infeed should never hold the bag back from the sewing head.

Sewing Head Speed Adjustment

When the sewing head is ideally synchronized, the sewing line should be parallel to the top of the bag if the bag is fed level with the conveyor. A variable speed pulley is used to adjust the sewing head speed by changing the diameter of the pulley. Up to approximately 10 feet per minute of adjustment in the synchronization with the conveyor is available.

When changing the diameter of the pulley, make sure the set screws are tightened on flat spots of the pulley threads. Adjustments are made at 1/4 turns.

Increasing the diameter of the sewing head pulley, slows the machine down:
decreasing it speeds the machine up.

Synchronization Variations

It is common and necessary to make adjustments to the synchronization of sewing heads and infeeds to conveyors.

Wear of the belts, pulleys and feed dog may require synchronization adjustments.

When a machine is cold, because of the slow starting and running of the sewing head, there can be synchronization differences. Run the machine steadily for a few minutes before closing any bags.

OIL

Check oil daily. Do not allow machine to run low. If the oil pressure gauge needle does not remain above the 10 pounds P.S.I. while machine is running, stop immediately. Refer to the maintenance area of this manual.

Remove accumulations of lint and dirt from looper area.

SKIPPED STITCHES or BROKEN THREAD

Examine the needle. If it is bent, dull or worn, replace it.

Verify that the needle and looper are threaded properly. Tweezers are provided with your machine; use them to thread the back end of the looper.

You may need to lubricate the thread. If your needle shows a build-up of glue, plastic or ink, or if your bags are treated with anti skid coating, you need to use Fischbein 5-102 thread lubricant. You may get this from your local Fischbein distributor.

Make sure there are no obstructions in the thread between the cone, the needle and looper.

Check the looper and needle guard adjustments.

LOOSE/TIGHT STITCHES

Check the needle thread pull off. If the stitch appears to be loose, raise the pull-off; if it looks too tight, lower the pull-off.

Check to see that all thread tensions are correct. Remember that the looper tension and the needle lever tension should be very light, whereas the needle thread tension should be quite firm.

UNEVEN STITCHING

Check the feed dog teeth. If they are worn and dull, replace the feed dog.

Check the presser foot spring pressure. It is pre-set at the factory at about 40 lbs.

Check that the height of the feed dog is set correctly.

Check the tension of the sewing head drive belt, and verify that the sewing head, power infeed, and conveyer are properly synchronized.

WEAR ON ESSENTIAL PARTS

If the looper or throat plate has any wear or nicks, replace them.

If the outside rows of teeth on the feed dog look worn or dull replace the feed dog.

Monitor the looper and needle guard adjustments.

MACHINE NOT CHAINING OFF

Is it properly threaded?

Check the needle thread pull-off.

Check the thread tensions.

Check that the needle is not worn, bent or dull.

Check the condition of the looper and the throat plate.

Is there any build-up on the needle?

Do you have the correct thread quality? Is it too thick or too thin. Using **Fischbein thread**, designed for use in these machines will help you eliminate thread related problems.

Check the looper and needle guard adjustments.

Check that the hinge bolt allows the presser foot to hinge freely.

Check that the presser foot is level and not worn.

Check center row of teeth on feed dog to make sure they are not too low.

FREQUENT NEEDLE BREAKS

Sewing too close to the contents of the bag can put undue stress and tension on the needle.

Is the operator pulling the bag through the machine, rather than allowing the bag to pass through at its own speed.

Make sure the needle is aligned in the presser foot slot in such a way that the needle does not rub on the presser foot.

Check the synchronization of sewing head to conveyor and infeed to sewing head.

Knives which are not cutting the thread cleanly between bags can cause needles to break. Replace the knives.

Check that the needle guard is in place and adjusted properly.

A 46 MINUTE SERVICE VIDEO IS AVAILABLE FROM YOUR FISCHBEIN DISTRIBUTOR TO FURTHER HELP SERVICING ALL STATIONARY FISCHBEIN MODELS.

SYNCHRONIZED SEWING HEAD OPERATING SPEED* Stitch Length

CONVEYOR SPEED	2 ST/IN	2½ ST/IN	2¾ ST/IN	3 ST/IN	3.3 ST/IN	3½ ST/IN
30 FT/MN	720 RPM	900 RPM	990 RPM	1080 RPM	1200 RPM	1260 RPM
35 FT/MN	840 RPM	1050 RPM	1155 RPM	1260 RPM	1400 RPM	1420 RPM
40 FT/MN	960 RPM	1200 RPM	1320 RPM	1440 RPM	1600 RPM	1680 RPM
45 FT/MN	1080 RPM	1350 RPM	1485 RPM	1620 RPM	1762 RPM	1890 RPM
50 FT/MN	1200 RPM	1500 RPM	1650 RPM	1800 RPM	1980 RPM	2100 RPM
55 FT/MN	1320 RPM	1650 RPM	1815 RPM	1980 RPM	2178 RPM	—
60 FT/MN	1440 RPM	1800 RPM	1980 RPM	2160 RPM	—	—
65 FT/MN	1560 RPM	1950 RPM	2145 RPM	—	—	—
70 FT/MN	1680 RPM	2100 RPM	—	—	—	—
75 FT/MN	1800 RPM	—	—	—	—	—

These RPM are for a 1:1 ratio. Usually the proper speed for each machine will vary slightly.
 A Model 90 head should run the same speed as the conveyor or up to 5% faster.
 A Model 91 head should run approximately 10% faster than the conveyor.

* To calculate R.P.M.s, convert stitches per inch to stitches per foot and multiply by conveyor speed. To calculate stitch length, divide R.P.M.s by conveyor speed. To calculate conveyor speed, divide R.P.M.s by stitch length.

FISCHBEIN

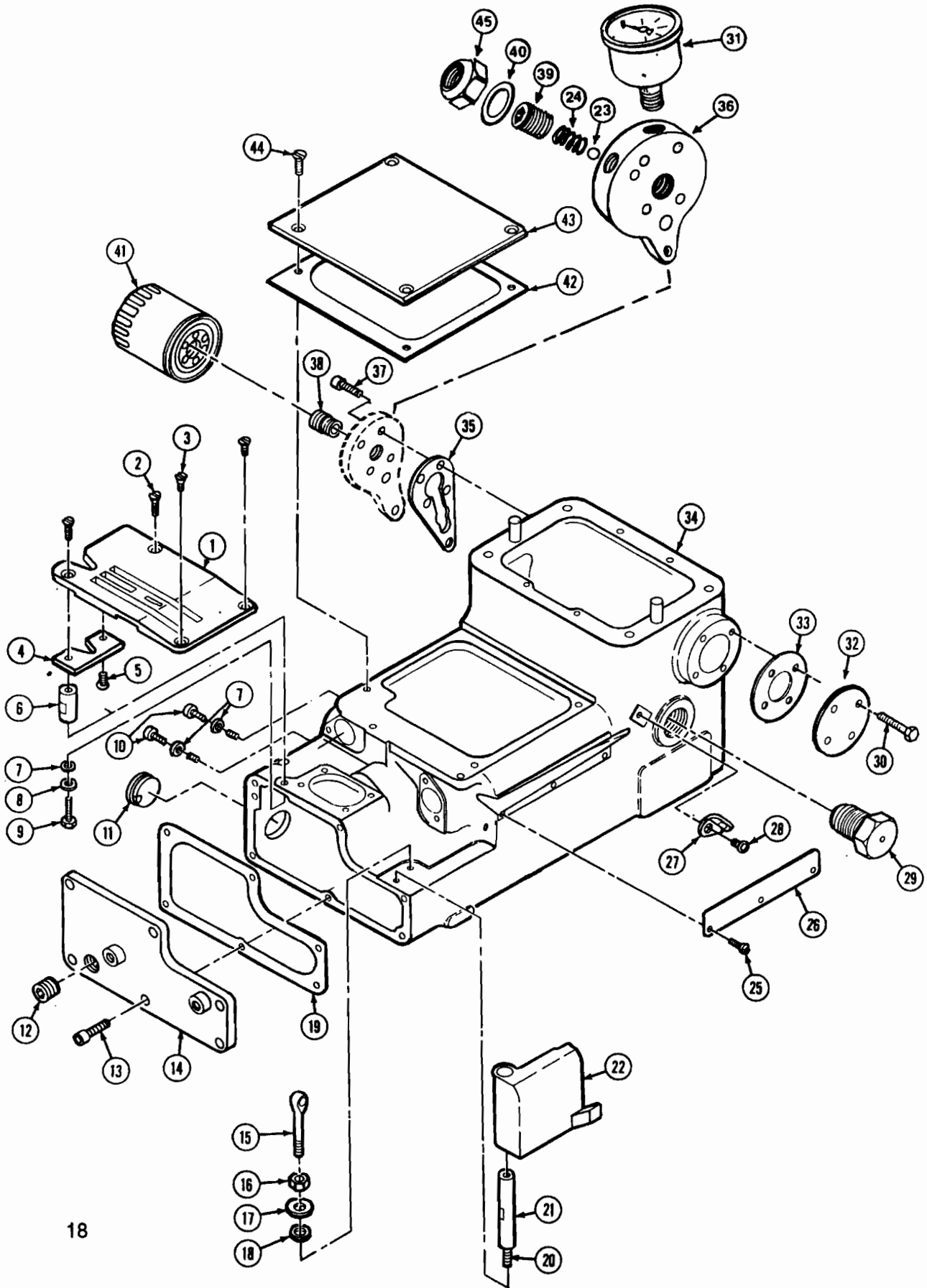

MAIN HOUSING

ITEM	QUAN.	PART.NO.	DESCRIPTION
1	1	10017	PLATE, THROAT
2	2	F103258	SCREW,FLAT HD #10-32x5/8
3	2	F103238	SCREW,FLAT HD #10-32x3/8
4	1	10091	KNIFE, STATIONARY
5	1	F83214	SCREW, FLAT HD#8-32x1/4
6	1	10015	POST, SHORT - THROAT PLATE
7	3	WN8	WASHER, NYLON
8	1	WF10	WASHER, FLAT#10
9	1	H103212	SCREW, HEX HD#10-32x1/2
10	2	B103214	SCREW, BINDING HD#10-32x1/4
11	1	10112	WINDOW, OIL LEVEL
12	1	10111	PLUG, DRAIN - MAGNETIC
13	6	SC103258	SCREW, SOC. CAP#10-32x5/8
14	1	15072	COVER, BOTTOM
15	1	10170	PULL-OFF - LOOPER THREAD
16	1	NH1420	NUT, HEX
17	1	WF14	WASHER, FLAT #14
18	1	10052	WASHER - NYLON
19	1	10093	GASKET, COVER - BOTTOM
20	1	SS10321	SCREW SOC.SET#10-32x1
21	1	10016	POST, LONG - THROAT PLATE
22	1	10005	DOOR, LOOPER
23	1	15069	BALL, CHROME
24	1	15078	SPRING, PRESSURE
25	3	B632316	SCREW, BINDING HD#6-32x3/16
26	1	10098	COVER, GROOVE - THREAD
27	1	10164	EYELET, THEAD - SHORT
28	1	SB103212	SCREW,SOC.BUTTON #10-32x1/2
29	1	10116	ASS'Y, PLUG - BREATHER
30	4	H103212	SCREW, HEX HD#10-32x1/2
31	1	15053	GAUGE, OIL PRESSURE #60
32	1	15079	PLATE, COVER - SIDE
33	1	10094	GASKET, MAIN SHAFT SEAL
34	1	15002	HOUSING, MAIN
35	1	10095	GASKET, COVER - MANIFOLD
36	1	15056	MANIFOLD, FILTER
37	5	SC103234	SCREW, SOC.CAP#10-32 N.C.x3/4
38	1	15062	NIPPLE, FILTER - OIL
39	1	15064	PLUG, ADJUSTING - MANIFOLD
40	1	15074	SEAL, NYLON
41	1	15054	CARTRIDGE, OIL - FILTER
42	1	10092	GASKET, COVER - TOP
43	1	10014	PLATE, COVER - TOP
44	4	F103238	SCREW, FLAT HD#10-32x3/8
45	1	11268	NUT, LOCK

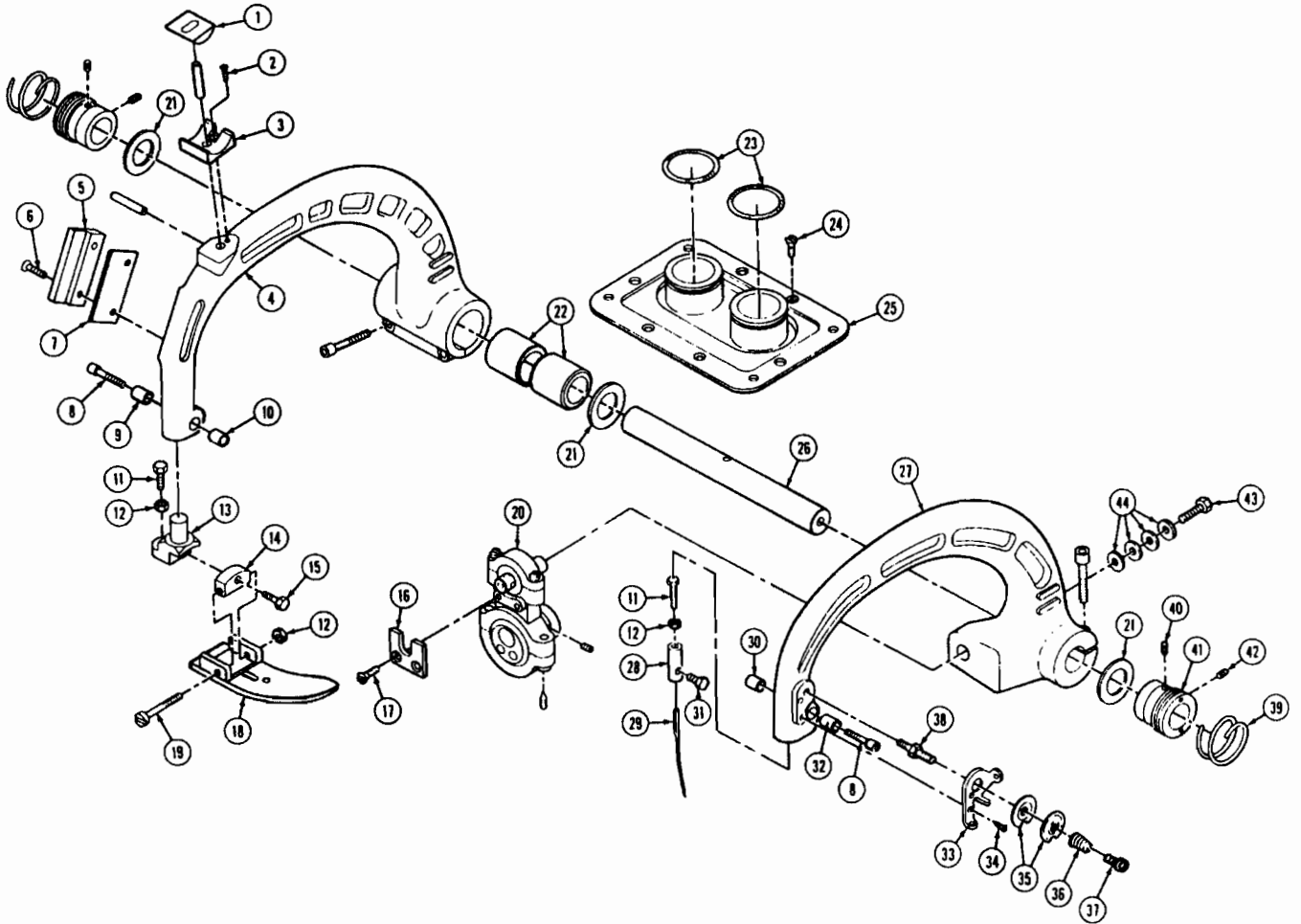

NEEDLE & PRESSER FOOT ASSEMBLIES

ITEM	QUAN.	PART NO.	DESCRIPTION
1	1	10190	PAD,SPRING-PRESSER FOOT
2	1	F63214	SCREW,FLAT HD#6-32x1/4
3	1	10189	CRADLE,PAD-PRESS.FT.SPG.
4	1	10004	LEVER,PRESSER FOOT
	2	SC14201	SCREW,SOC.HD CAP#14-20x1
	2	PS14112	PIN, ROLL
5	1	10163	CLAMP,BEARING-SHEET
6	2	F103258	SCREW,FLAT HD#10-32x5/8
7	1	10162	SHEET,BEARING-PR.FT.LV.GD.
8	2	SC63234	SCREW,SOC.HD CAP#6-32x3/4
9	1	10213	PLUG,CLAMP-DRILLED(PRESS.FT.)
10	1	10214	PLUG,CLAMP-TAPPED(PRESS.FT.)
11	2	H103234	SCREW,HEX #10-32x3/4-GRADE 5
12	3	NH1032	NUT
13	1	10155	SHANK, PRESSER FOOT
14	1	10156	BLOCK, HINGE-PRESSER FOOT
15	2	H103234	SCREW,HEX #10-32x3/4-GRADE 5
16	1	10048	RETAINER, ROD-CONNECTING
17	2	F103238	SCREW, FLAT HD310-32x3/8
18	1	10185	PRESSER FOOT
	1	10285	PRESSER FOOT,(RIP CORD)
19	1	10182	BOLT,HINGING-PRESSER FOOT
20	1	15018	ROD,CONNECTING-NEEDLE DRIVE
	1	SS142038CP	SCREW,SET-CONE PT.#14-20x3/8
	1	SS142014	SCREW,SET#14-20x1/4
21	3	T3129	WASHER, THRUST
22	2	10029	BUSHING,LEVER-PRESSER FOOT
23	2	10128	SPRING,GARTER-LEVER SEAL
24	4	F103238	SCREW,FLAT HD#10-32x3/8
25	1	10137	SEAL, LEVERS
26	1	10026	SHAFT, LEVERS
27	1	15073	LEVER, NEEDLE
	2	SC1420114	SCREW,SOC.HD CAP#14-20x1/4
28	1	10031	CHUCK, NEEDLE
29	1	C100-S	NEEDLE
30	1	10212	PLUG,CLAMP-TAPPED(NEEDLE LV.)
31	1	10011	SCREW, CLAMP NEEDLE
32	1	10211	PLUG,CLAMP-DRILLED(NEEDLE LV.)
33	1	10166	GUIDE,THREAD-(NEEDLE LEVER)
34	2	F54038	SCREW,FLAT HD#5-40x3/8
35	2	10119	DISC, TENSION-SMALL
36	1	10009	SPRING,TENSION-(NEEDLE LEVER)
37	1	B103238	SCREW,BINDING HD#10-32x3/8
38	1	10113	STUD, TENSION-(NEEDLE LEVER)
39	2	10023	INSERT,THREAD-LVR SHFT BUSH'G
40	2	SS103238	SCREW,SET #10-32x3/8
41	2	10025	BUSHING, SHAFT LEVERS
42	2	SS1032316	SCREW,SET #10-32x3/16
43	1	H142812	SCREW,HEX #14-28x1/2-GRADE 5
44	4	15076	WASHER, SPRING #1/4

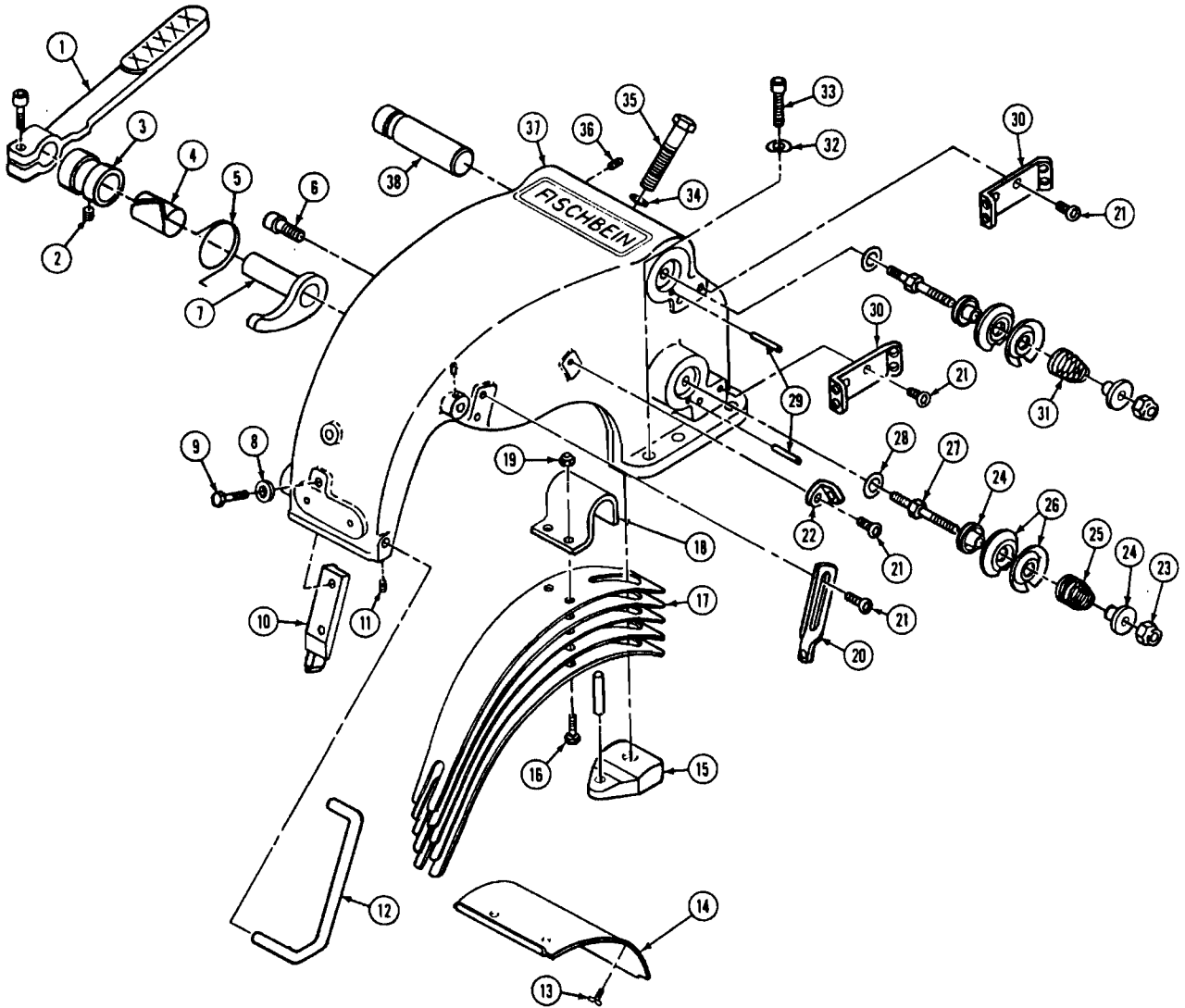

LEVERS HOUSING ASSEMBLY

ITEM	QUAN.	PART NO.	DESCRIPTION
1	1	10141	LEVER,LIFTER-PRESSURE FOOT
	1	SC142034	SCREW,SOC.CAP 1/4-20x3/4
2	1	SS142014	SCREW, SET #14-20x1/4
3	1	10139	BUSHING,LIFTER-PRESSER FOOT
4	1	10186	LINER,BUSHING-LIFTER LEVER
5	1	10187	SPRING, LIFTER LEVER
6	1	SC5161858	SCREW, STOP-LIFTER LEVER
7	1	10142	CAM,LIFTER-PRESSER FOOT
8	2	WS10	WASHER, SPRING #10
9	2	H103278	SCREW, HEX HD #10-32x7/8
10	1	10161	GUIDE, LEVER-PRESSER FOOT
11	2	SS1032516	SCREW, SET #10-32x5/16
12	1	10188	GUARD, TENSION-NEEDLE
13	2	B103238	SCREW, BINDING HD #10-32x3/8
14	1	10123	COVER, GUARD - LEVERS
15	1	10146	PLATE,PRESS. FT. SPRG.-TAPPED
	1	PS141	PIN, ROLL
16	2	H103234	SCREW, HEX HD #10-32x3/4
17	5	10145	SPRING, PRESSER FOOT
18	1	10144	CLAMP, SPRING-PRESSER FOOT
19	2	1-178	NUT, LOCK
20	1	10171	PULL-OFF, NEEDLE THREAD
21	7	SB103212	SCREW,SOC BUTTON 10-32x1/2
22	1	10164	EYELET, THREAD-SHORT
23	2	NH1428L	NUT,#14-28-LOCKING
24	4	10114	SLEEVE, TENSION
25	1	10008	SPRING, TENSION-LOOPER THREAD
26	4	10120	DISC, TENSION-LARGE
27	2	10115	STUD, TENSION
28	2	11120	WASHER, LOCK
29	2	PS18114	PIN,RETAINING-TENSION DISC
30	2	10165	EYELET, THREAD-LONG
31	1	10007	SPRING, TENSION-NEEDLE THREAD
32	4	10234	WASHER, SPRING
33	4	SC516181	SCREW, SOC.CAP #516-18x1
34	1	WF38	WASHER
35	1	H3824134	SCREW, ADJ.#38-24x1 3/4
36	1	SS142038	SCREW, SET #14-20x3/8
37	1	10002	HOUSING, LEVERS
38	1	10143	SHAFT, SPRING-PRESSER FOOT

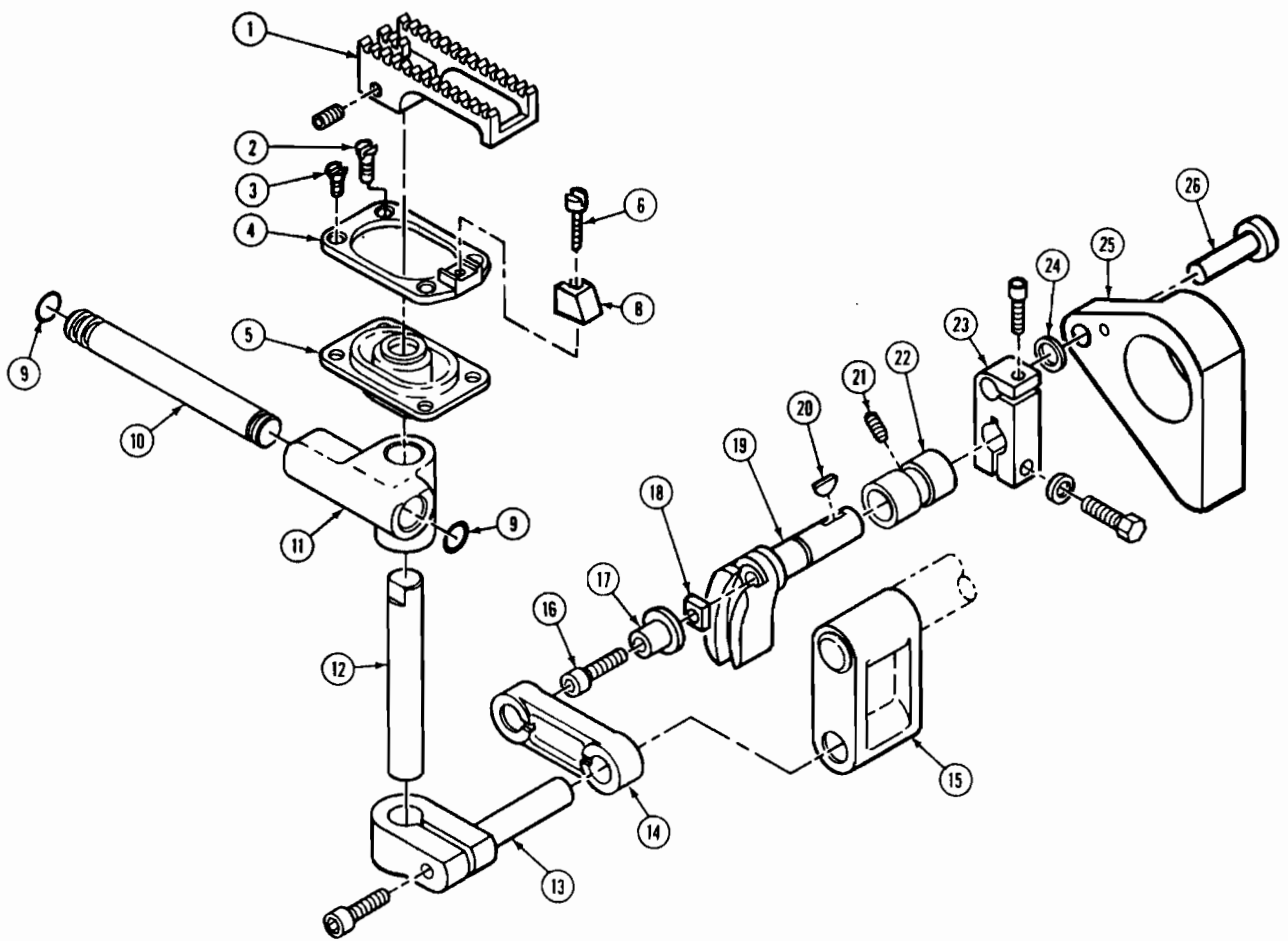

FEED ASSEMBLY

ITEM	QUAN.	PART NO.	DESCRIPTION
1	1	10078	DOG, FEED CTR.ROW OF TEETH HAS 4 TEETH
		10079	DOG, FEED CTR.ROW OF TEETH HAS 3 TEETH
	1	SS1032516	SCREW,SET#10-32x5/16
2	1	F103238	SCREW,FLAT HD#10-32x3/8
3	3	F103212	SCREW,FLAT HD#10-32x1/2
4	1	10177	HOLDER, GUARD-NEEDLE
5	1	10077	SEAL, DOG - FEED
6	1	P540916	SCREW,PAN HD #5-40x9/16
8	1	10174	GUARD, NEEDLE
9	2	10075	RING, "O"
10	1	10074	ROD, SLIDE - FEED
11	1	10073	SLIDE, FEED
12	1	10072	ROD, CARRIER - FEED DOG
13	1	10070	CLAMP,ROD-FEED DOG CARRIER
	1	SC142078	SCREW,SOC.HD CAP#14-20x7/8
14	1	10069	LINK, STROKE - FEED
15	1	10071	LINK, LIFT - FEED
16	1	SC142878	SCREW,SOC.HD CAP#14-28x7/8
17	1	10068	PIVOT,ADJUSTING-FEED STROKE
18	1	10067	NUT,PIVOT-FEED STROKE ADJ'G.
19	1	10066	LEVER,SLOTTED-FEED ROCKER
20	1	T3192	KEY
21	1	SS1032516	SCREW, SET#10-32x5/16
22	1	10109	BUSHING,SHAFT-FEED ROCKER
23	1	10063	LEVER,PIN-FEED ROCKER
	1	SC54012	SCREW,SOC.HD CAP#5-40x1/2
	1	H103234	SCREW,HEX #10-32x3/4-GRADE 5
	1	WF10	WASHER, FLAT#10
24	1	10215	WASHER, THRUST
25	1	15070	ROD,CONNECT'G-PRIM.FEED STK.
26	1	10064	PIN,ROD-FEED STROKE CONNECT.

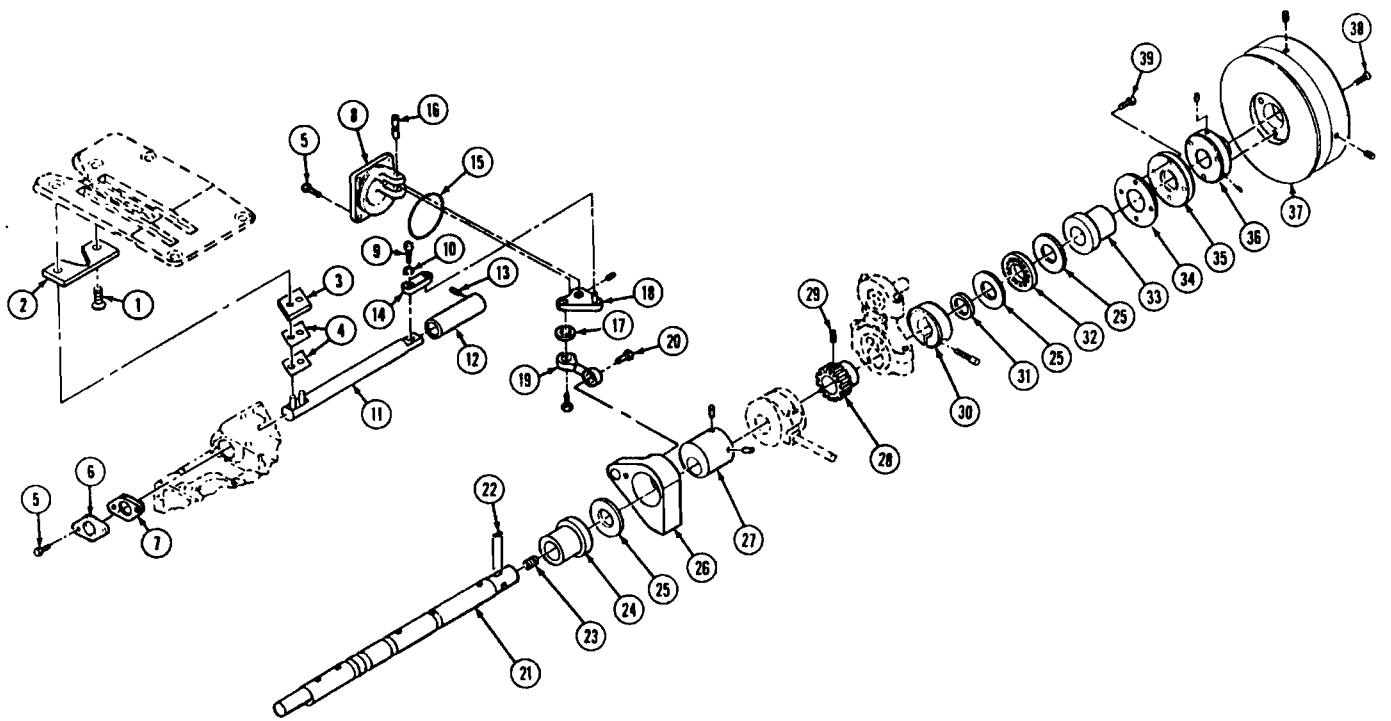

MAIN SHAFT & KNIFE ASSEMBLY

ITEM	QUAN.	PART NO.	DESCRIPTION
1	1	F83214	SCREW,FLAT HD#8-32x1/4
2	1	10091	KNIFE, STATIONARY
3	1	10090	KNIFE, MOVING
4	2	10089	SPRING, KNIFE
5	6	H103212	SCREW,HEX HD310-32x1/2
6	1	10076	ASSEMBLY,SEAL-KNIFE SHAFT
7	1	10058	GASKET, LOOPER SHAFT
8	1	10085	BRACKET, PIVOT - KNIFE
9	1	10087	SCREW, PIVOT - KNIFE
10	1	11120	WASHER, LOCK
11	1	10088	SHAFT, KNIFE
12	1	10056	BUSHING, SHAFT - KNIFE
13	1	SS1032516	SCREW,SET#10-32x5/16
14	1	10086	LINK, KNIFE
15	1	10084	RING, "O"
16	1	10083	SHAFT,BELL CRANK-KNIFE
17	1	WF10	WASHER, FLAT#10
18	1	10082	CRANK, BELL - KNIFE
	1	SS540316	SCREW,SET#5-40x3/16
19	1	10080	ASSEMBLY,CONNECT'G ROD-KNIFE
20	2	H103258	SCREW,HEX HD 10-32x5/8-GRD.5
21	1	10045	SHAFT, MAIN
22	1	T3192	KEY
23	1	10125	PLUG, PIPE - MAINSHAFT
24	1	15042	BUSHING,MAIN SHAFT-NEEDLE END
25	3	T3129	WASHER, THRUST
26	1	15070	ROD,CONNECT'G-PRIM.FEED STRK.
27	1	10061	ECCENTRIC, STROKE - FEED
	1	SS142038	SCREW, SET#14-20x3/8
	1	SS142038CP	SCREW,SET-CONE PT.#14-20x3/8
28	1	15016	GEAR, DRIVE - PUMP
29	1	SS832316CP	SCREW,SET #8-32x3/16 CONE PT.
	1	SS832316	SCREW,SET #8-32x3/16
30	1	15043	COLLAR, LOCK-MAIN SHAFT
	1	SC142858	SCREW,SOC.HD CAP#14-28x5/8
31	1	15032	"O" RING
32	1	P4024	BEARING THRUST
33	1	15041	BUSHING,MAIN SHAFT-DRIVE END
34	1	10094	GASKET, MAIN SHAFT SEAL
35	1	10035	ASSEMBLY, SEAL-MAIN SHAFT
36	1	10038	HUB, PULLEY
	2	SS142038	SCREW, SET#14-20x3/8
37	1	10199	PULLEY, ADJUSTABLE
	2	SS142038	SCREW, SET#14-20x3/8
38	3	F103258	SCREW, FLAT HD#10-32x5/8
39	4	SC103212	SCREW, SOC.HD CAP#10-32x1/2

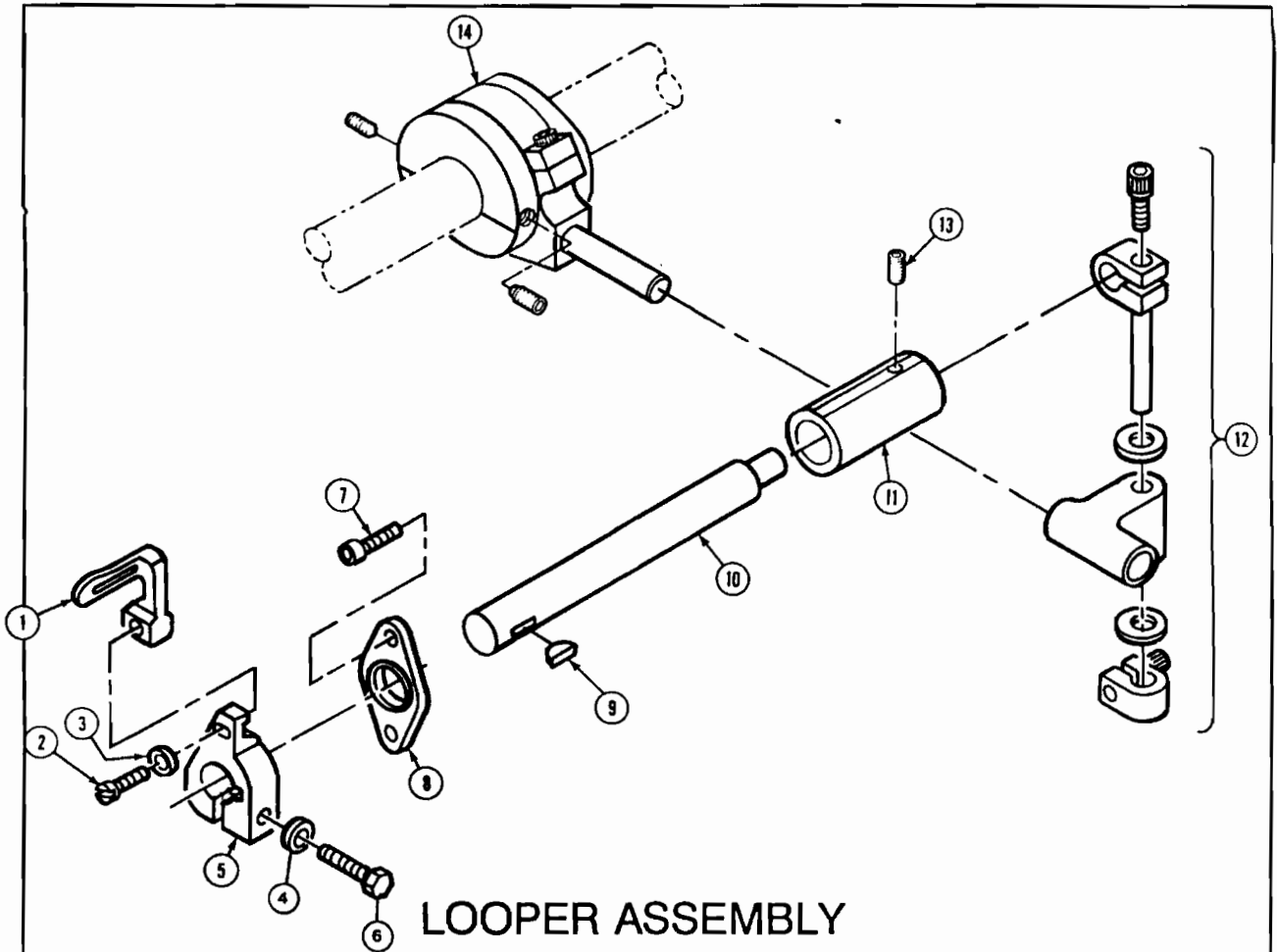

ITEM	QUAN.	PART NO.	DESCRIPTION
1	1	10060	LOOPER (TWO THREAD)
2	1	P540916	SCREW, PAN HD.#5-40X9/16
3	1	WF5	WASHER #5
4	1	WF10	WASHER, FLAT #10
5	1	10159	HOLDER, LOOPER
6	1	H103234	SCREW,HEX #10-32x3/4 GRADE 5
7	2	H103212	SCREW,HEX HD#10-32x1/2
8			
9	1	T3192	KEY
10	1	10055	SHAFT, LOOPER
11	1	10056	BUSHING, SHAFT - LOOPER
12	1	10173	ASS'Y, PIVOT - LOOPER
	2	15066	THRUST WASHER
	1	15065	CLAMP
	1	15039	PIN, PIVOT - LOOPER
	1	10153	KNUCKLE, PIVOT - LOOPER
	1	H103258	SCREW,HEX HD#10-32x58
13	1	SS1032516	SCREW, SET #10-32x5/16
	1	WF10	WASHER, FLAT #10
14	1	10150	ASS'Y CAM - LOOPER
	1	SS103258CPL	SCREW,SET-CONE PT.#10-32x5/8
	1	SS103212L	SCREW,SET#10-32x1/2-NYLOC

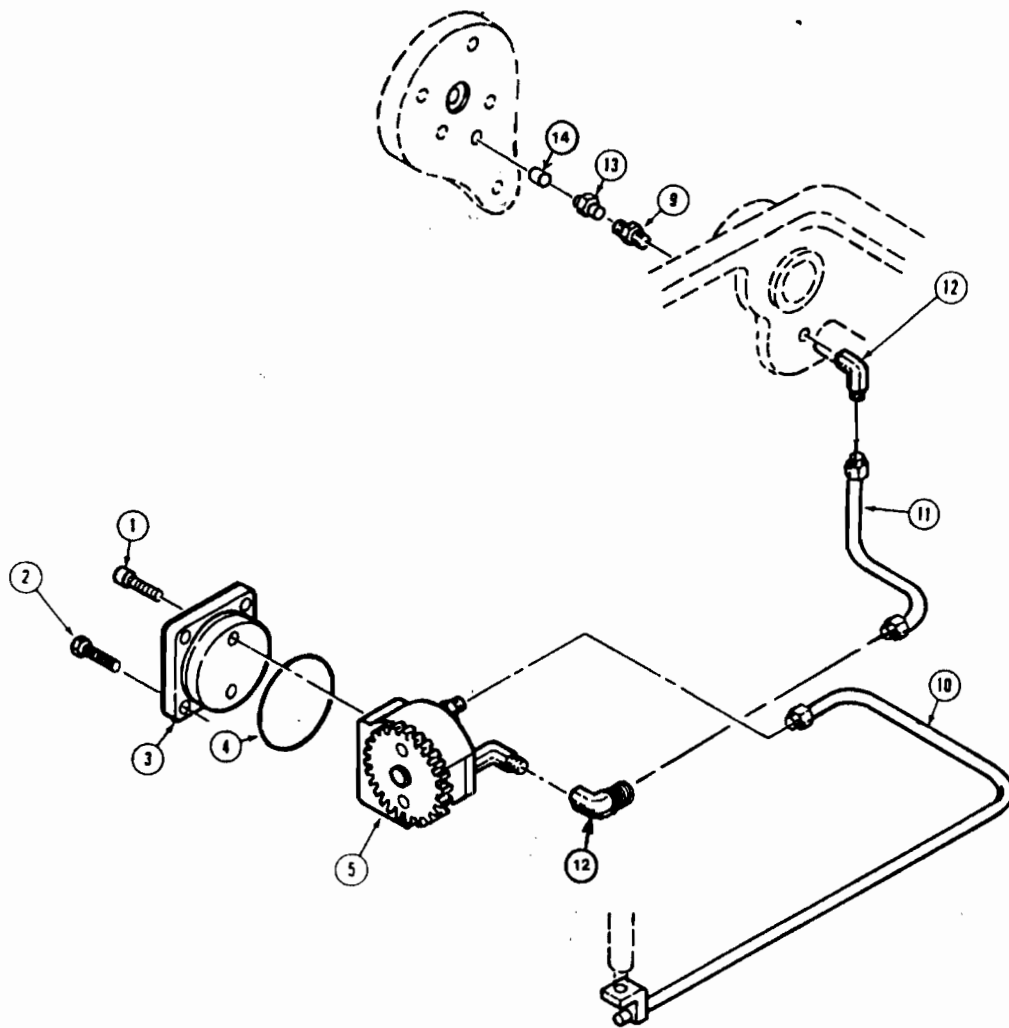

OIL PUMP ASSEMBLY

ITEM	QUAN.	PART NO.	DESCRIPTION
1	2	SC103234	SCREW,SOC.CAP #10-32x3/4
2	4	H103212	SCREW, HEX HD #10-32x1/2
3	1	15015	MOUNT PUMP
4	1	10084	RING "O"
5	1	15003	ASSEMBLY GEAR-PUMP
	1	15087	FITTING, ELBOW
	1	15059	FITTING, PIPE STRAIGHT
6	2	15059	FITTING, PIPE STRAIGHT
7	1	15050	OIL LINE, SUPPLY
8	1	15093	OIL LINE, PRESSURE
9	2	15092	FITTING, COMPRESSION ELB
10	1	15088	TUBING, COPPER
11	1	A1882	BUSHING, NEOPRENE